

TECHNICAL MANUAL

**OPERATOR'S, ORGANIZATIONAL, DIRECT
SUPPORT, AND GENERAL SUPPORT
MAINTENANCE MANUAL INCLUDING
REPAIR PARTS LIST**

FOR

**TESTER, HYDRAULIC
MODEL PHT-100-6-G418-1
NSN 4910-00-868-6871**

(SCHROEDER BROS. CORP.)

HEADQUARTERS DEPARTMENT OF THE ARMY

JUNE 1981



**OPERATOR'S, ORGANIZATIONAL, DIRECT SUPPORT, AND GENERAL SUPPORT
MAINTENANCE MANUAL INCLUDING REPAIR PARTS LIST**

FOR

**TESTER, HYDRAULIC
MODEL PHT-100-6-G418-1
(NSN 4910-00-868-6871)**

REPORTING OF ERRORS

You can help improve this manual. If you find any mistakes or if you know of a way to improve the procedures, please let us know. Mail your letter, DA Form 2028 (Recommended Changes to Publications and Blank Forms), or DA Form 2028-2, located in the back of this manual direct to: Commander, US Army Armament Materiel Readiness Command, ATTN: DRSAR-MAS, Rock Island, IL 61299. A reply will be furnished direct to you.

Manufactured by: Schroeder Brothers Corp.
Nichol Avenue Box 72
McKees Rocks, PA 15136

Procured under Contract No DAAA09-79-C-4593

This technical manual is an authentication of the manufacturers' commercial literature and does not conform with the format and content specified in AR 310-3, Military Publications. This technical manual does, however, contain available information that is essential to the operation and maintenance of the equipment.

INSTRUCTIONS FOR REQUISITIONING PARTS

NOT IDENTIFIED BY NSN

When requisitioning parts not identified by National Stock Number, it is mandatory that the following information be furnished the supply officer.

- 1 - Manufacturer's Federal Supply Code Number - 08832
- 2 - Manufacturer's Part Number exactly as listed herein.
- 3 - Nomenclature exactly as listed herein, including dimensions, if necessary.
- 4 - Manufacturer's Model Number - Model PHT-100-6-G418-1
- 5 - Manufacturer's Serial Number (End Item)
- 6 - Any other information such as Type, Frame Number, and Electrical Characteristics, if applicable.
- 7 - If DD Form 1348 is used, fill in all blocks except 4, 5, 6, and Remarks field in accordance with AR 725-50.

Complete Form as Follows:

- (a) In blocks 4, 5, 6, list manufacturer's Federal Supply Code Number - 08832 followed by a colon and manufacturer's Part Number for the repair part.
- (b) Complete Remarks field as follows:
Noun: (nomenclature of repair part)
For: NSN: 4910-00-868-6871
Manufacturer: Schroeder Brothers Corp.

Model: PHT-100-6-G418-1 Serial: (of end item)

Any other pertinent information such as Frame Number, Type, Dimensions, etc.

PORTABLE HYDRAULIC TESTER

WITH THE TESTER, MOTORS, VALVES, CYLINDERS AND OTHER HYDRAULIC EQUIPMENT CAN BE CHECKED AT RATED FLOWS AND PRESSURES.

THE TESTER MEASURES OIL FLOW, (GPM) GALLONS PER MINUTE, PRESSURE (PSI) AND TEMPERATURE (°F) DEGREES FAHRENHEIT.

OIL LEAKAGE IN HYDRAULIC MOTORS, VALVES, CYLINDERS RESULT IN A LOSS OF FLOW AND SOMETIMES A LOSS OF PRESSURE.

WITH A KNOWLEDGE OF A HYDRAULIC SYSTEM TO BE TESTED AND APPROPRIATE USE OF THE TESTER, MOST AREAS OF HYDRAULIC MALFUNCTION CAN BE PINPOINTED WITHOUT DISMANTLING OR TEARING DOWN THE SYSTEM.

THE LOADING VALVE PERMITS SIMULATION OF LOAD OR WORK.

CAUTION:
LOAD VALVE LEVER IS CAPABLE
OF VERY HIGH PRESSURES

- A. KEEP LOAD PRESSURE WITHIN THE TESTER AND SYSTEM RATING.
- B. DO NOT EXCEED DESIGN PRESSURE OF THE SYSTEM UNDER TEST.
- C. WHEN A HIGH PRESSURE LINE IS INCORRECTLY CONNECTED TO THE EXIT PORT (LOW PRESSURE RETURN SIDE) OF THE TESTER, BACK PRESSURE OCCURS. THE PROTECTIVE BLOWOUT PLUG RELEASES OIL IN THE TESTER CASE WHEN THE BACK PRESSURE REACHES 3000-3500 PSI.

HYDRAULIC POWER

FLOW AND PRESSURE EQUALS HYDRAULIC POWER. THE PUMP AND/OR MOTOR PRODUCES BOTH LOW AND PRESSURE.

A HYDRAULIC SYSTEM ACCOMPLISHES WORK WHEN SEALS ARE GOOD, COMPONENTS ARE NOT WORN, TOLERANCES ARE AS SPECIFIED, WHEN THE RELIEF VALVES ARE OPERATING PROPERLY AND WHEN THE EQUIPMENT IS BEING OPERATED WITHIN DESIGN CAPABILITY.

INTERNAL WEAR IN A PUMP PERMITS SLIPPAGE OR BYPASSING OF THE OIL BY THE GEARS, VANES OR PISTONS AND RESULTS IN THE INABILITY OF THE PUMP (UNDER PRESSURE) TO DELIVER THE RATED VOLUME OF OIL.

WHEN FLOW AND OR PRESSURE IS REDUCED, HYDRAULIC POWER IS REDUCED.

HYDRAULIC PUMPS AND SYSTEMS ARE PROTECTED AGAINST EXCESSIVE PRESSURE BY RELIEF VALVE

AN IMPROPER RELIEF VALVE SETTING EITHER ENDANGERS THE SYSTEM WITH TOO MUCH PRESSURE OR PERMITS RELIEF OF PRESSURE PRIOR TO DEVELOPING THE MAXIMUM SPECIFIED PRESSURE OF THE SYSTEM.

CYLINDERS AND VALVES FUNCTION WHEN FLOW AND PRESSURE IS RECEIVED. LEAKAGE IN THE CONTROL VALVE REDUCES WORKING FLOWS AND PRESSURE DELIVERED DOWN STREAM OF THE VALVE.

PORTABLE HYDRAULIC TESTER

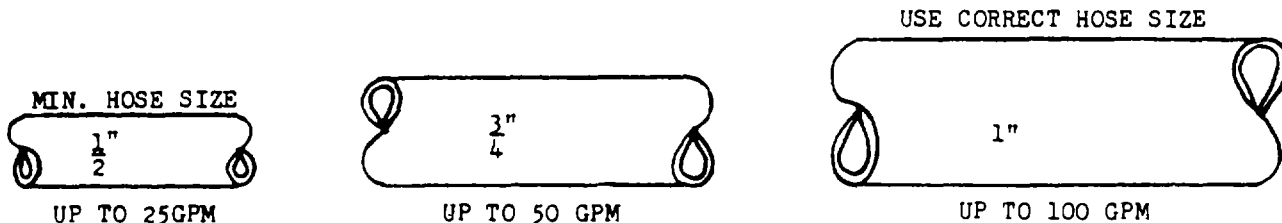

DRAWING 1
 LOW PNSSURE RETURN LINE (MUST BE AS LARGE OR LARGER TN HIGH PRESSURE LINE AND AS SHORT AS POSSIBLE) BACK PRESSURE MUST NOT EXCEED 100 PSI.
 INTRODUCE ONLY PETROLEUM BASE HYDRAULIC FLUIDS INTO UNIT

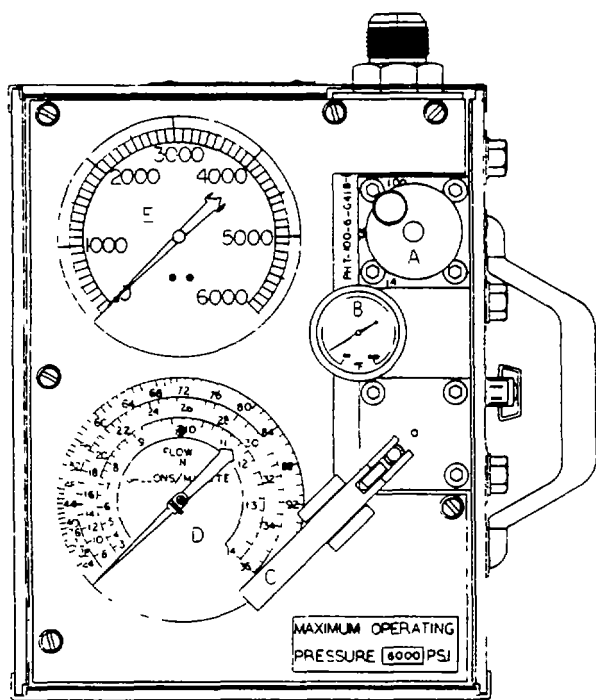

DRAWING 3

- A ORIFICE SELECTOR
- B TEMPERATURE GAUGE
- C LOAD LEVER
- D FLOW GAUGE
- E PRESSURE GALUE

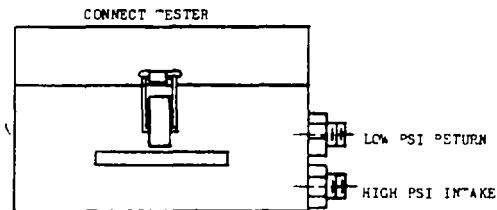

DRAWING 2

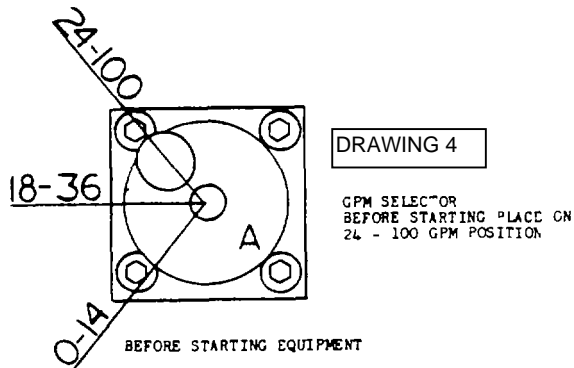

DRAWING 4

IN ALL TESTS, MAKE CERTAIN THE DRIVE MOTOR IS OPERATING AT SPECIFIED RPMs WHEN THE TESTER LOAD LEVER IS DE-PRESSED AND THE READINGS ARE TAKEN.

PRE-OPERATIONS CHECK LIST

BEFORE STARTING EQUIPMENT

1. WHAT ARE THE MANUFACTURERSE RATINGS FOR THE SYSTEM, PUMP, RPM, GPM, PSI AND TEMPERATURE?
2. CONNECT THE TESTER AS IN DRAWINGS 2 AND 5 OR AS IN DRAWINGS 2 AND 6 WITH THE LINE BLOCKED AT POINT A.
3. CHECK THE TESTER CONNECTIONS AND THE SYS-TEM. BE SURE TO KNOW WHICH COMPONENTS ARE SUBJECTED TO THE TEST OIL COLUMN AND PRESSURE DEVELOPED BY THE TESTER LOAD VALVE. REPEAT THIS CHECK AFTER EACH CHANGE OF SYSTEM CONNECTION OR VALVE POSITION.
4. START THE EQUIPMENT. ASCERTAIN THAT OIL IS FLOWING FREELY THROUGH THE TESTER AND RETURNING TO THE SYSTEM RESERVOIR. IDLE THE EQUIPMENT UNTIL THE OIL HEATS TO OPERATING TEMPERATURE, (CA'JTION-IF OIL IS NOT RETURNING TO THE RESERVOIR, CUT THE EQUIPMENT OFF AND CHECK CONNECTIONS TOTHE TESTER, THE EQUIPMENT, THE VALVE SETTINGS AND THE OIL LEVEL IN THE EQUIPMENT RESERVOIR.)
5. SET THE ORIFICE TO THE FLOW SCALE WHICH PERMITS THE CLOSEST MID-SCALE FLOW READINGS ON FLOW GAUGE, DRAWINGS 3, ITEM A AND DRAWING 4.

TESTING

6. ACCELERATE THE ENGINE TO OPERATING RPM AND HOLD AT THAT RPM.
7. READ GPM ON THE TESTER FLOW GAUGE DRAWING 3.
8. LIFT LOAD LEVER C TO OUTBOARD POSITION AND GRADUALLY APPLY PRESSURE UNTIL OPERATING PSI IS OBTAINED.
9. AT OPERATING RPM, TEMPERATURE REPEAT VALVE PSI READ GAUGES E,B AND D.
10. COMPARE THE GPM READINGS WITHOUT PRESSURE IN STEP 7 WITH READINGS IN 9. SUBTRACT 9 FROM 7. CORRELATE WITH THE PUMP GPM RATING. DETERMINE THE EFFICIENCY OF THE PUMP IN REGARD TO THE MANUPAC-TURERIS RATINGS AND ACCEPT BILITY.

SYSTEMS TEE TEST

11. CHANGE TESTER SYSTEM CONNECTION TO PERMIT THE TEE TEST
12. IN A SYSTEM SUCH AS THE ONE SHOWN IN DRAWING 6, POSITION A, SHIFT THE CONTROL VALVES AND FULLY EXTEND THE CYLIJNDERS. THE PUMP WILL THEN OFFER A COLUMN OF OIL TO THE SYSTEM AND THE TESTER. DEPRESS THE TESTER LOAD VALVE C, DRAWING 3, UNTIL THE SYSTEM OPERATING PRESSURE IS ACHIEVED. THE OIL OUTPUT OF THE PUMP MUST THEN COME OVER THE TESTER LOAD VALVE AT OPERATING PRESSURE OR SLIP PAST A WORN, LEAKING COMPONENT IN THE SYSTEM.

PUMP TEST

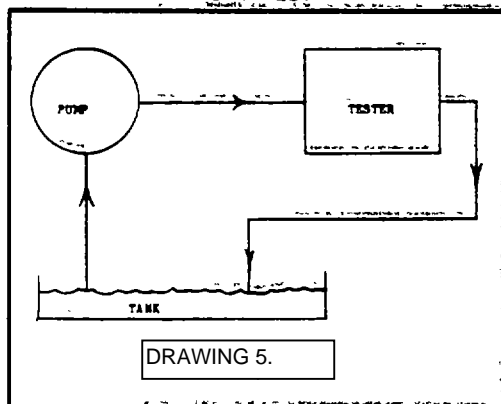

DRAWING 5.

SYSTEMS ANALYSIS WITH TEE TEST

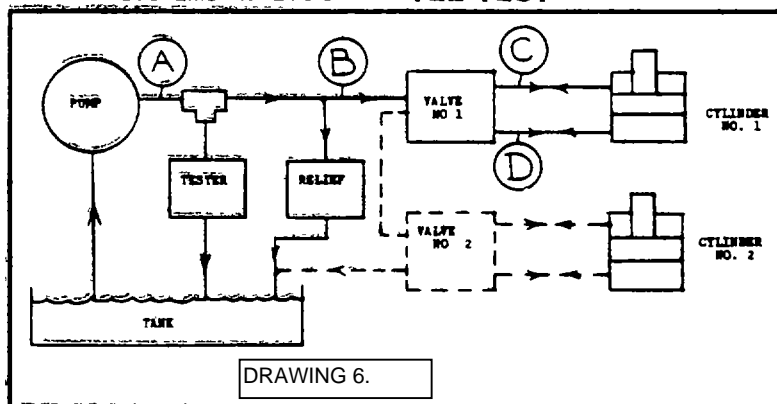

DRAWING 6.

13. READ THE GPM ON THE TESTER AT OPERATING PSI. CORRELATE THESE READINGS WITH PUMP TEST STEP 9. IF THERE IS A LOSS IN GPM OVER THE TESTER, THERE IS LEAKAGE, SLIPPAGE OR A MALFUNCTIONING COMPONENT IN THE SYSTEM.
 14. CHECK THE RELIEF VALVE. BLOCK LINE AS IN DRAWING 6, BLOCK B OR BY CLOSING THE VALVES. DEPRESS THE TESTER LOAD LEVER UNTIL THE RATED PRESSURE OF THE RELIEF VALVE IS ACHIEVED. WHEN THE RELIEF VALVE OPENS, A SUDDEN DROP IN GPM AND PSI WILL BE NOTED ON THE TESTER INSTRUMENTS.

NOTE THE PSI AT WHICH THE RELIEF OPENS AND COMPARE WITH SYSTEM SPECIFICATIONS. CORRECT RELIEF SETTING IF NECESSARY.
 15. REMOVE BLOCK B WITH CONTROL VALVE 1 OPEN AND 2 CLOSED FULLY EXTENDED, THE CYLINDER AND READ GPM AND PSI -AT OPERATING TEMPERATURE AND RPM.
 16. REPEAT SAME AS IN 15 CLOSING VALVE 1 AND OPEN 2.
 17. IN THIS SYSTEM IF READINGS IN PARAGRAPH 15 AND 16 VARY AND ARE LESS THAN THE READINGS IN PARAGRAPH 14, OIL IS BEING LOST IN EITHER THE VALVES OR CYLINDER.
 18. ANALYZE THESE RESULTS AND DETERMINE IF BLOCKS AND TEST SHOULD BE MADE AT POINTS C AND D.
 19. THE CONSIDERATION IN ALL ANALYSIS IS THAT IF AT ANY POINT IN TEST THERE IS A LOSS OF GPM SHOWN ON THE TESTER AT OPERATING RPM, TEMPERATURE AND PSI, THE OIL IS LEAKING PAST ONE OF THE COMPONENTS RECEIVING FLOW AND PRESSURE.
 20. BY OPERATING WITH THE TEE TO TESTER SHIFTING VALVES, DEAD ENDING CYLINDERS AND BLOCKING LINES, A HYDRAULIC SYSTEM CAN BE SEGMENTED AND EXAMINED.
- THIS TYPE OF ANALYSIS WILL LOCATE FAULTY COMPONENTS IN PLACE ON THE SYSTEM.

**IF YOUR TESTER SHOWS STRANGE READINGS
MAKE THE FOLLOWING CORRECTIONS AND REPAIRS**

- | | | |
|---|---|---|
| <p>21. FLOW GAUGE NEEDLE MOVES WILDLY AND ERRATICALLY.</p> | <p>AIR LAK IN PUMP SUCTION LINE.</p> <p>NOT ENOUGH OIL IN RESERVOIR TANK.</p> | <p>CHECK ALL PUMP AND PUMP LINE CONNECTIONS AND SEALS.</p> <p>CHECK AND FILL RESERVOIR TANK.</p> |
| <p>22. FLOW GAUGE NEEDLE SHOWS BELOW CORRECT PUMP FLOW AT BOTH NO LOAD AND LOAD OR HIGH PRESSURE READING.</p> | <p>SUCTION PROBLEM RESTRICTION IN THE SUCTION LINES, CLOGGED SUCTION STRAINER, LOW OIL LEVEL.</p> <p>INLET AND OUTLET CONNECTIONS REVERSED.</p> | <p>CLEAN LINES AND STRAINER OR ADD OIL.</p> <p>CONNECT INLET AND OUTLET PORTS CORRECTLY.</p> |
| <p>23. PRESSURE DOES NOT REGISTER WHEN LOAD VALVE IS DEPRESSED, AND FLOW GAUGE IS BELOW ZERO.</p> | <p>EXCESSIVE SACK PRESSURE.</p> | <p>LIMIT RETURN LE TO 100 PSI.</p> |
| <p>24. FLOW GAUGE FREEZES IN ANY POSITION.</p> | <p>INCORRECT ORIFICE</p> <p>INLET AND OUTLET CONNECTIONS REVERSED.</p> | <p>CHOOSE PROPT FLOW GAUGE SCALE.</p> <p>BLOWOUT PLUG MUST BE REPLACED.</p> |
| <p>25. OIL IS AUDIBLY RELEASED INTO THE TESTER CASE.</p> | <p>PROTECTIVE BLOWOUT PLUG HAS RUPIURED.</p> <p>BACKPRESSURE ROSE TO 3000- 3500 PSI</p> | |
| <p>26. REPLACING BLOWOUT PLUG WHEN BLOWOUT PLUG HAS RUPTURED-</p> <p>A. SHUT DOWN SYSTEM</p> <p>B. REMOVE CONNECTION</p> <p>C. REMOVE TESTER INLET AND OUTLET FITTINGS</p> <p>D. DRAIN OIL FROM CASE ON THE BENCH</p> <p>E. REMOVE PLEXIGLASS COVER FROM TESTER</p> | | <p>F. REMOVE LARGE SCREWS FROM HANDLE SIDE END OF TESTER CASE</p> <p>G. LIFT TESTER FROM CASE AND CLEAN TESTER</p> <p>H. LOCATE BRASS BLOWOUT PLUG MOUNTER IN BLOCK UNDER THE PLEXIGLASS.</p> <p>I. REPLACE BLOWOUT WITH EXTRA FROM THE COVER</p> <p>J. RETURN TESTER TO CASE</p> <p>K. INSERT MOUNTING SCREWS</p> <p>L. REPLACE PLEXIGLASS COVER</p> |

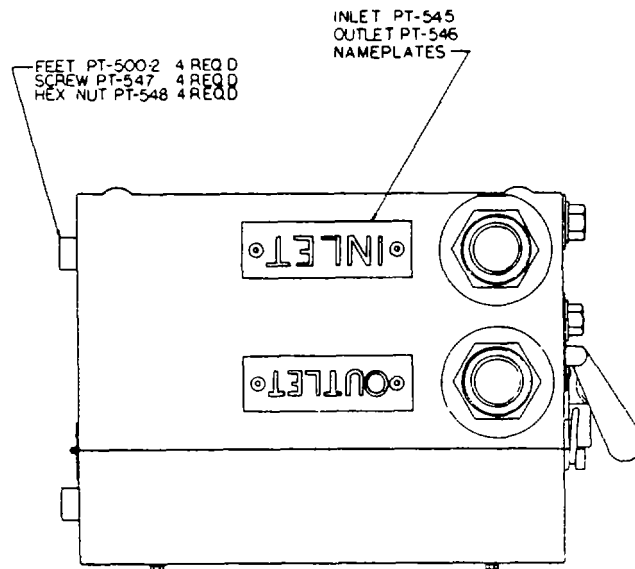
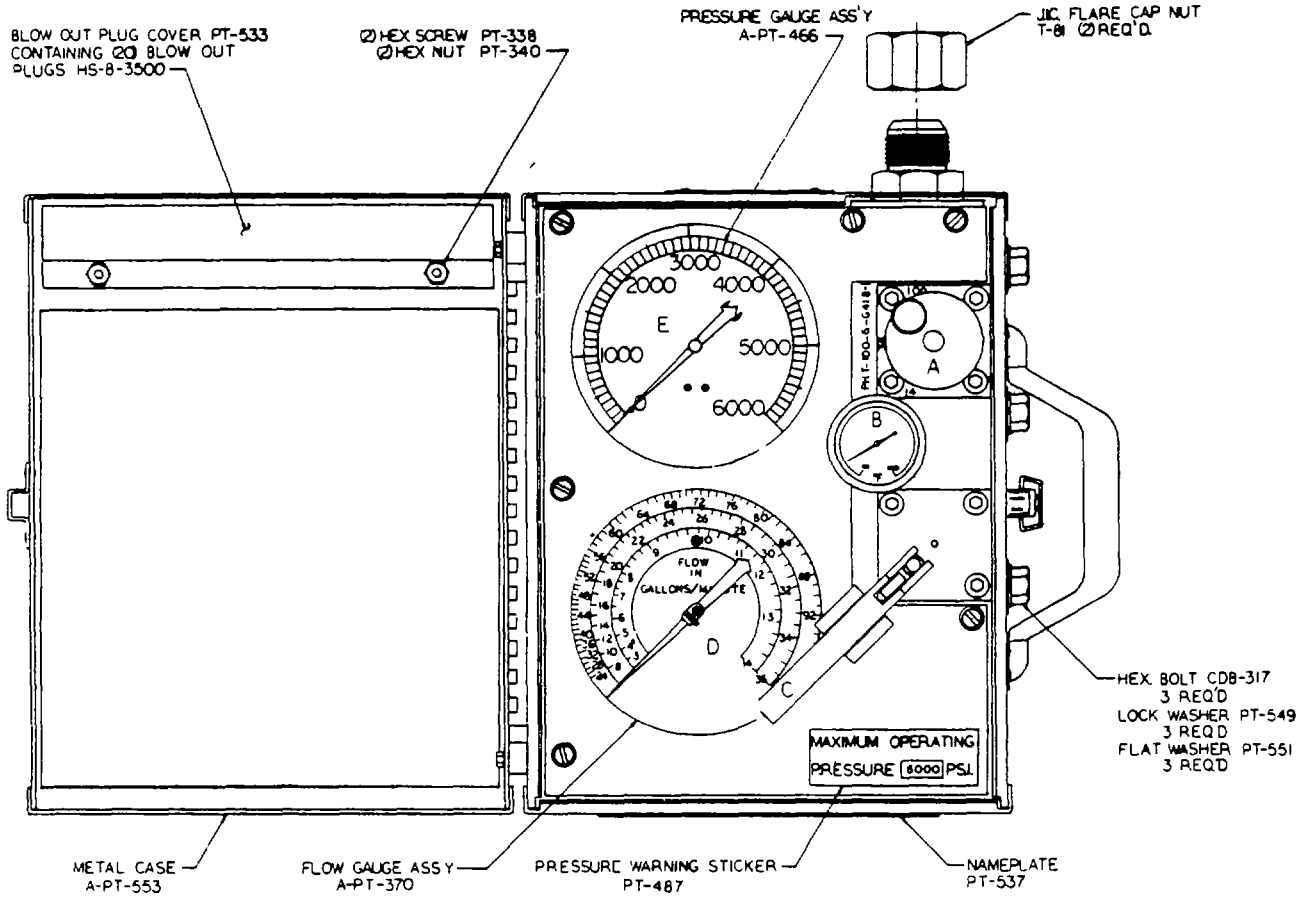

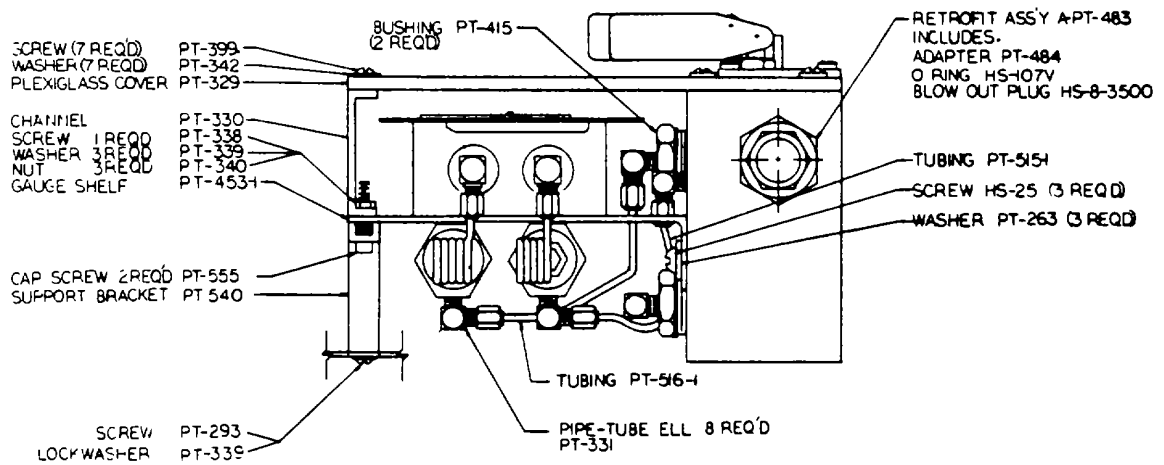
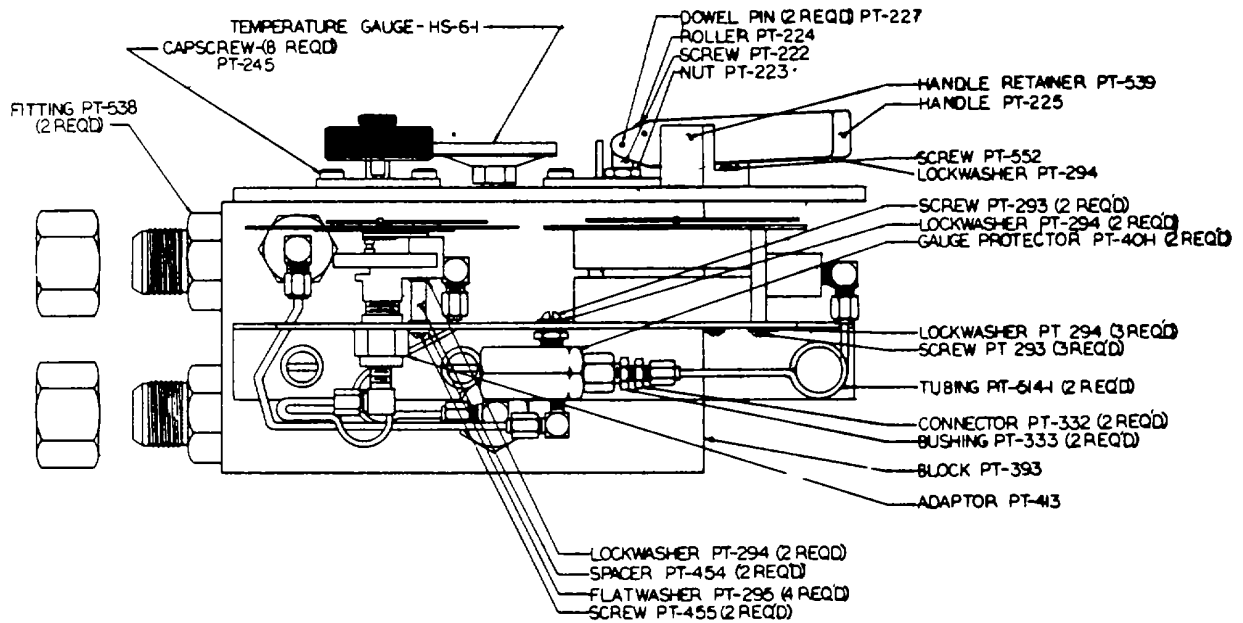

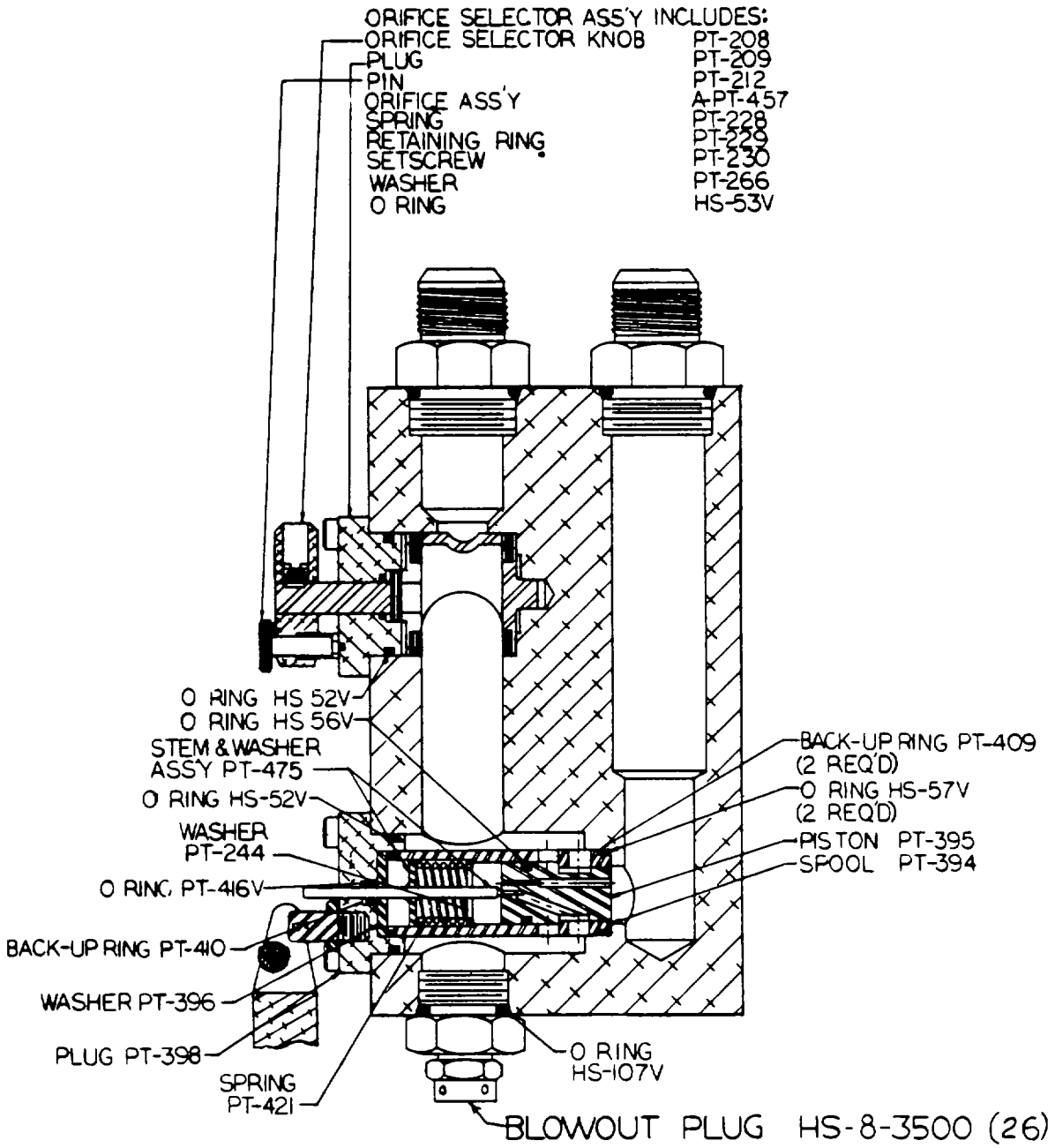

By Order of the Secretary of the Army:

Official:

J C. PENNINGTON
Major General, United States Army
The Adjutant General

E. C. MEYER
General, United States Army
Chief of Staff

Distribution:

To be distributed in accordance with Special List.

☆ U.S. GOVERNMENT PRINTING OFFICE : 1992 0 -311-831 (60323)

RECOMMENDED CHANGES TO EQUIPMENT TECHNICAL PUBLICATIONS



THEN... JOT DOWN THE DOPE ABOUT IT ON THIS FORM, CAREFULLY TEAR IT OUT, FOLD IT AND DROP IT IN THE MAIL!

SOMETHING WRONG WITH THIS PUBLICATION?

FROM: (PRINT YOUR UNIT'S COMPLETE ADDRESS)

DATE SENT

PUBLICATION NUMBER

PUBLICATION DATE

PUBLICATION TITLE

BE EXACT... PIN-POINT WHERE IT IS

PAGE NO.	PARA-GRAPH	FIGURE NO.	TABLE NO.
----------	------------	------------	-----------

IN THIS SPACE TELL WHAT IS WRONG AND WHAT SHOULD BE DONE ABOUT IT:

TEAR ALONG PERFORATED LINE

PRINTED NAME, GRADE OR TITLE, AND TELEPHONE NUMBER

SIGN HERE:

DA FORM 2028-2 JUL 79

PREVIOUS EDITIONS ARE OBSOLETE.

P.S.—IF YOUR OUTFIT WANTS TO KNOW ABOUT YOUR RECOMMENDATION MAKE A CARBON COPY OF THIS AND GIVE IT TO YOUR HEADQUARTERS.

TM 9-4910-726-14&P TESTER, HYDRAULIC-1981

PIN : 049655-000